

ECLIPSE INFORMATION GUIDE
 AUTOMATIC TEMPERATURE CONTROL VALVES
 Series "CR"

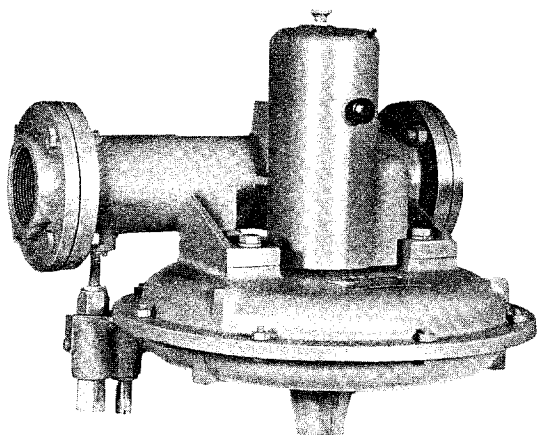

Eclipse Series "CR" Valves are simple, but reliable, air operated valves used for hi-low control of air to combustion systems. Air flow through the valve is controlled by an inexpensive solenoid valve requiring only a small amount of electrical power.

1.0 VALVE OPERATION (Refer to Figure 1)

- 1.1 If a thermo-electric or thermocouple type of instrument is used, a solenoid bleed valve is installed in line "D". (See Bulletin M-501.)
- 1.2 The air line being controlled connects at "A". "B" is outlet air pipe connection. Some of the air passes through "N" and through line "O". In passing through jet "I" and the venturi "Q", this stream of air creates a suction in the chamber "R" and chamber "C" which pulls the diaphragm "M" downward. This brings down rod "J" and ratchet which meshes with the trunion "H" and swings the butterfly "K" toward the open position. Adjusting screw "P" controls the speed of valve action by limiting the amount of bleed area between chambers "R" and "C". The knurled nut "F", which is adjustable, fixes the amount the valve will open. The valve will remain in this position as long as the air passes through "I", "Q", and "D".

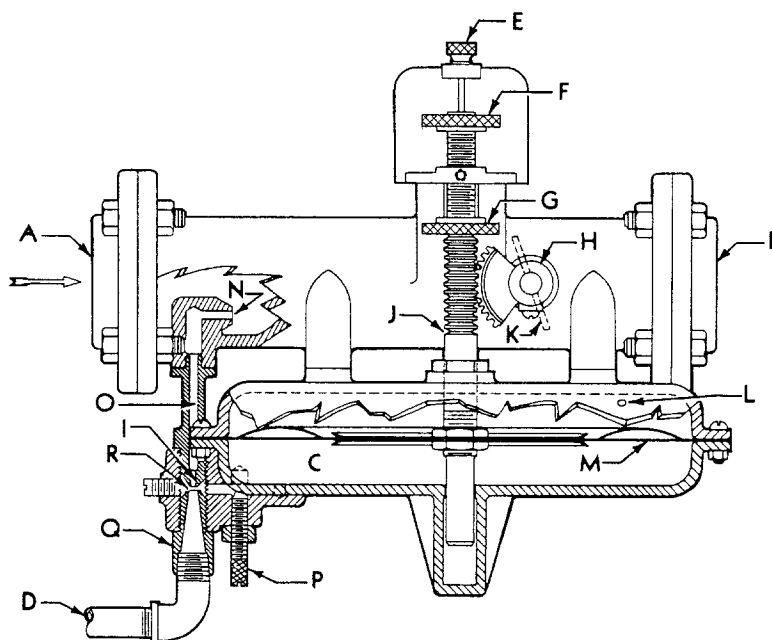

FIGURE 1



ECLIPSE COMBUSTION

- 1.3 When the desired temperature is reached in the medium or chamber being heated, the solenoid, acting in response to the sensitive element, will automatically shut off the line "D". Since there is no longer an escape for the air passing through "I", it will pass into chambers "R" and "C". This changes the suction to a pressure equal to full line pressure under the diaphragm "M", forcing it upward and driving the butterfly "K" toward the closed position. The amount it will close is fixed by the adjustable knurled nut "G".
- 1.4 After the knurled nuts "F" and "G" have been set to give the desired maximum and minimum operation, the rod "E" is slipped into place. This rod fits into slots on the circumference of the nuts insuring an absolutely positive setting which will not be altered by vibration.
- 1.5 When the minimum and maximum settings have been completed, the speed of valve action can be set by adjusting the by-pass screw "P" to suit the desired speed of valve control.
- 1.6 The above valve action is automatically repeated each time the temperature rises to or falls below the desired point. In this way the temperature is held practically constant. The variation will depend to a great extent on the action of the thermostat or pyrometer equipment.
- 1.7 The opening "L" is to permit free breathing of the chamber above the diaphragm to the atmosphere. THIS OPENING SHOULD NEVER BE PLUGGED.
- 1.8 In 1-1/4" and 1-1/2" valves, the position of the butterfly "K" is indicated by a slot in the end of the butterfly shaft. For all other valves, a key-way in trunnion "H" is positioned 90° from the plane of the butterfly face.

2.0 CONNECTION OF CONTROL VALVE PIPING IN THE AIR LINE (Refer to Figure 1)

- 2.1 Connect valve at "A" to air supply, allowing air to flow through valve in direction of the arrow.
- 2.2 When installing a "CR" Control Valve, it is preferable to place a manual blast gate or air butterfly valve on the "A" side of the "CR" Valve rather than the "R" side. The air supply can then be conveniently shut off in case the "CR" Valve is to be removed for repair or replacement.

3.0 OPERATION AND ADJUSTMENT (Refer to Figure 1)

(To determine proper high and low fire settings for the "CR" Valve, install a pressure gauge at the burner(s) and adjust the "CR" Valve as follows to achieve desired air pressure or mixture pressure:)

3.1 Minimum Supply

- 3.1.1 Adjust nut "G" to set the minimum supply. To increase the minimum supply, adjust nut "G" toward nut "F".
- 3.1.2 To decrease the minimum supply, adjust nut "G" away from nut "F".

3.2 Maximum Supply

- 3.2.1 Adjust nut "F" to set the maximum supply. To decrease the maximum supply, adjust nut "F" toward nut "G".
- 3.2.2 To increase the maximum supply, adjust nut "F" away from nut "G".

3.3 Speed of Operation

- 3.3.1 To decrease the speed of operation, adjust screw "P" inward.
- 3.3.2 To increase the speed of operation, adjust screw "P" outward.

3.4 Locking

- 3.4.1 After the maximum and minimum air supply has been set, insert rod "E".
- 3.4.2 It may be necessary to turn nut "G" and nut "F" slightly to allow rod "E" to slip into place. This slight adjustment will not make any noticeable difference in the setting.
- 3.4.3 DO NOT use wrenches on nuts "G" and "F" or rod "E".
- 3.4.4 Replace cover.

4.0 CONNECTING ELECTRIC SOLENOID VALVE (CRS) - (Refer to Figure 1)

- 4.1 The solenoid valve is connected to the CR Valve in line "D".
- 4.2 Connect the electric current on the solenoid valve to the electric temperature control.
- 4.3 Be sure the solenoid electric current rating is for use with the electric current characteristics available.
- 4.4 It is necessary that the solenoid be in a vertical position. This can be taken care of by means of pipe fittings.

5.0 CLEANING OF AIR JET (Refer to Figure 2)

- 5.1 Loosen locknut, 3, and move up to hex nut, 2, on threaded tube. Thread nuts 2 and 3 together all of the way down to air jet nut, 4. Loosen nut 4 until threads disengage, and remove entire assembly.
- 5.2 Carefully clean opening in air jet, 4, and drilled opening in threaded tube, 2, with pipe cleaner or soft bristle brush. Do not use wood, metal, or wire brush to clean jet since they will damage brass parts.
- 5.3 Re-assemble by reversing the above procedure and replace rubber compression washer, 1, if worn. Tighten all parts with wrench. Be sure you do not damage threads. Tighten down against rubber washer so there is no air leakage.

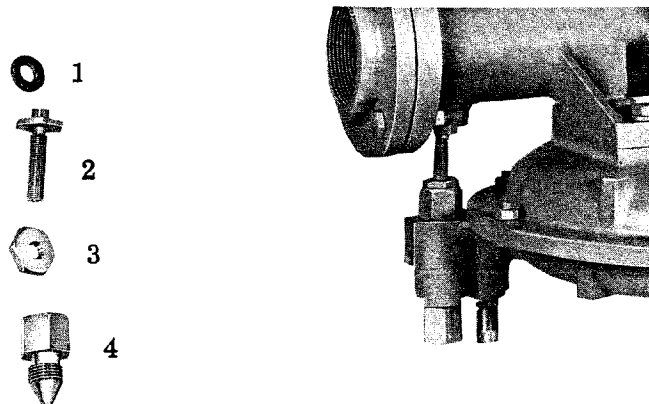

FIGURE 2



Offered By:

Power Equipment Company
2011 Williamsburg Road
Richmond, Virginia 23231
Phone (804) 236-3800
Fax (804) 236-3882

www.peconet.com